

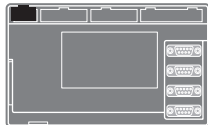

## 5-WAY CONNECTOR

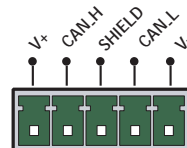

This is a 5 way 3.81mm pitch connector. The connector is used both to provide the 24 Volt power to the MC206X and provide connections for I/O expansion via Trio's P316 and P325 CAN I/O expanders. A 24V dc, Class 2 transformer or power source must be provided as this powers the unit.



This 24 Volt input is internally isolated from the I/O 24 Volts and the +/-10V voltage outputs.

*The 24V (V+) and 0V (V-) MUST be connected as they power the MC206X. The Shield MUST also be connected to ground as it provides the EMC screen for the Motion Coordinator. The CAN connections are optional.*

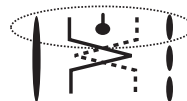

## SERIAL CONNECTIONS

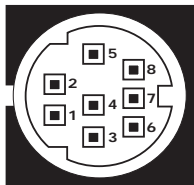
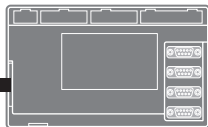

### Serial Connector A

Pin	Function	Note
1	Internal V 5	Serial port P0 #
2	Internal V 0	
3	RS232 transmit	
4	RS232 V 0	
5	RS232 receive	
6	+5V utput	For fibre-optic adaptor.
7	Externally buffered output (TTL)	
8	Externally buffered input (TTL)	

Note: Port 0 is the default programming port for connection to the PC running Motion Perfect.

## SERIAL CONNECTIONS

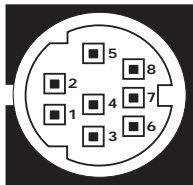

## Serial Connector B

Pin	Function	Note
1	RS485 Data In A Rx+	Serial Port #2
2	RS485 Data In B Rx-	
3	RS232 transmit	Serial Port #1
4	RS232 0V / RS485 0V	
5	RS232 receive	Serial Port #2
6	Internal v 5	
7	RS485 Data Out Z Tx-	Serial Port #2
8	RS485 Data Out Y Tx+	

## I/O CONNECTOR 1

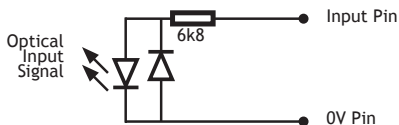
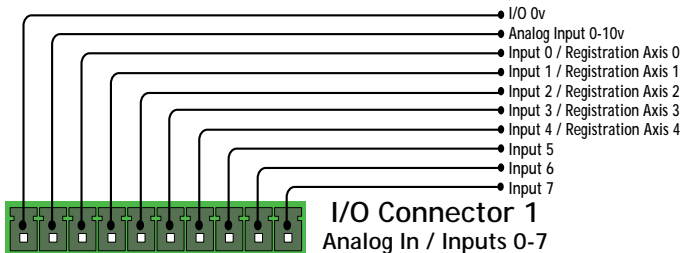
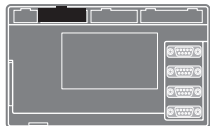

## I/O CONNECTOR 2

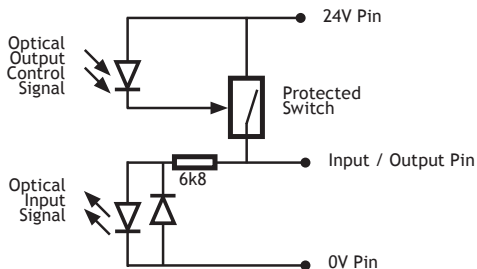
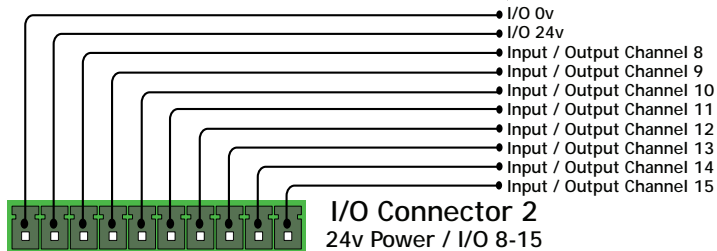
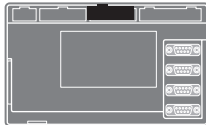

## I/O CONNECTOR 3

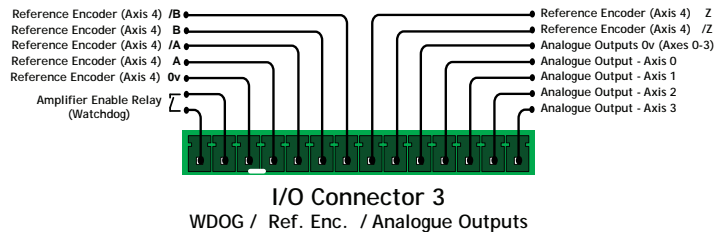

**AMPLIFIER  
ENABLE  
(WATCHDOG)  
RELAY OUTPUT**

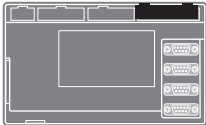

An internal relay is used to enable external amplifiers when the controller has powered up correctly and the system and application software are ready. The amplifier enable is a single pole solid state relay with a normally open “contact”. The enable relay contact will be open circuit if there is no power on the controller OR a following error exists on a servo axis OR the user program sets it open with the WDOG=OFF command.

***ALL STEPPER AND SERVO AMPLIFIERS MUST BE INHIBITED WHEN THE AMPLIFIER ENABLE OUTPUT IS OPEN CIRCUIT***

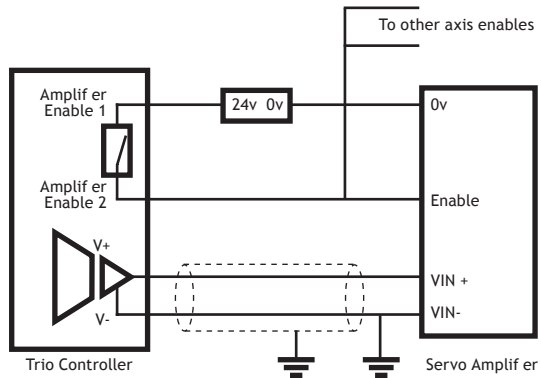

**ANALOGUE INPUT**

**AIN0: 0 TO 10V**

**ANALOGUE OUTPUTS**

**AOUT 0 TO AOUT 4**

Output: +/-10V at 5mA

Output impedance: 100 Ohms.

Common 0V return. Isolated from I/O & Encoders.

## STEPPER OUTPUTS / ENCODER INPUTS

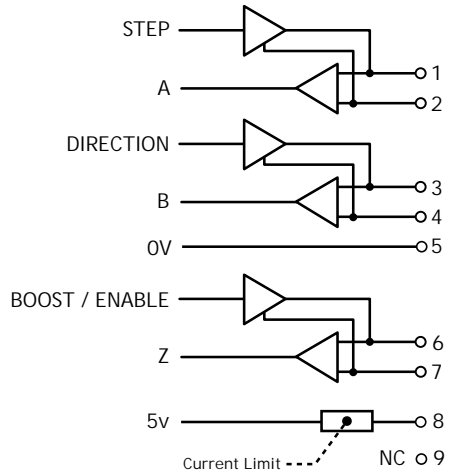
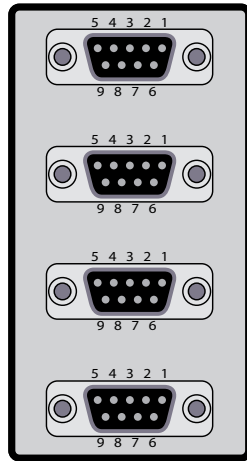

Pin	Servo Axis	Stepper Axis
1	Enc. A	Step +
2	Enc. /A	Step -
3	Enc. B	Direction +
4	Enc. /B	Direction -
5	0V	0V
6	Enc. Z	Boost +
7	Enc. /Z	Boost -
8	5V*	5V*
9	Not Connected	Not Connected

\* Current limit is 150mA total, shared between all outputs (including daughter board if fitted).

## GROUNDING AND SHIELDING

Ensure that:

1. The shield pin is grounded as close to the MC206X as possible.
2. 0V, V- and E- connections are NOT used for terminating screens.
3. Pin 5 of Encoder/Stepper plug is connected to 0V on drive.
4. Encoder cable screen is clamped to 9 way D shell.
5. MC206X 24V supply has common 0V with the drive(s)

*When wiring MC206X Stepper outputs to a differential input stepper drive, use the 0V and shield connections shown for the encoder. The stepper drive must have its common 0V connected to the MC206X 24V return. (24V -)*

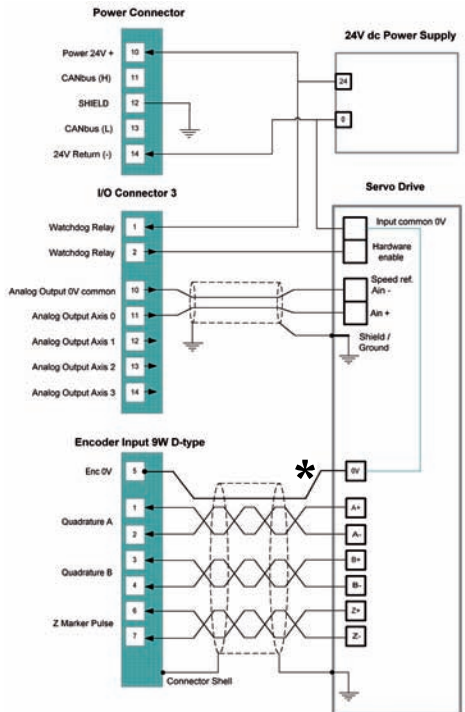

\* Encoder input 0V MUST be connected to pin 5

## USE OF DAUGHTER BOARD

Follow the wiring instructions for the daughter board that is installed. In addition, because the daughter board front panel is fitted within the MC206X plastic case, a separate shield ground wire should be connected to all screened cables. This includes all cables terminated with a D-type multi-pin connector.

## LED ERROR CODES

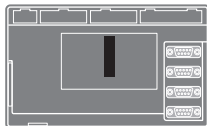

OK	STATUS	No power or critical fault
OK	STATUS	Normal operation
OK	STATUS	Enable relay open
OK	STATUS	Enable relay energised
OK ST	ATUS	Error in motion system (f ashing)

Good quality screened cables should be used for the serial ports and for the USB link. The serial ports, USB port and CANbus port are not galvanically isolated, therefore the 0V return MUST be connected to all peripheral devices. In addition, bond together the 0V (24V return) terminals of all system components so as to minimise current flowing in the serial cables.

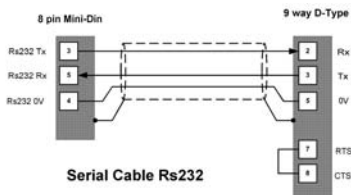
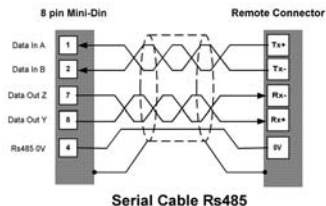

### **Trio Motion Technology Ltd.**

Shannon Way, Tewkesbury,  
Glos. GL20 8ND. UK

Tel: +44 1684 292333

Fax: +44 1684 297929

Email: sales@triomotion.com

Website: www.triomotion.com

### **Trio Motion Technology LLC**

1000 Gamma Drive, Suite 206,  
Pittsburgh PA 15238, USA

Tel: +1 412 968 9744

Fax: +1 412 968 9746

Email: enovak@triomotion.com

Website: www.triomotion.com

### **Trio Shanghai**

Tompson Centre  
118 Zhang Yang Road, B1701,  
Pudong New Area, Shanghai,  
200122, China

Tel/Fax: +86-21-58797659

HP: +8613816137446

Email: triomotion@126.com

Website: www.triomotion.com